



XLT43E

**PRELIMINARY
SPECIFICATIONS**

TWO-WAY COMPACT TRAPEZOIDAL LOUDSPEAKER SYSTEM

APPLICATIONS:

- Sound Reinforcement / Portable PA
- Clubs
- Houses of Worship
- Health Clubs
- Sport Facilities
- Industrial A/V
- Keyboard Systems

FEATURES:

- 1" Titanium HF Driver with HF Level Switch
- Ferrofluid-cooled 15" LF
- Switchable Passive / Biamp Modes
- PowerSense™ DDP Circuit with Front/Rear Indicators
- Trapezoidal Enclosure for Arraying
- Steel Bar-Handles and Input Panel
- Black Paint Exterior

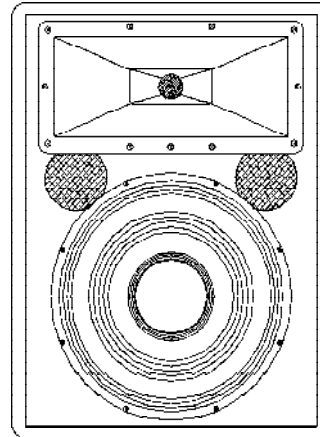

DESCRIPTION

The XLT43E is a compact, trapezoidal, two-way full-range loudspeaker system. High-efficiency and clear, articulate output is combined with a smooth frequency response. A unique 1" titanium diaphragm HF compression driver couples to a large, 90 x 40 degree Pattern Control horn. A Ferrofluid-cooled 15" woofer provides excellent bass response and high power handling. These components are matched to a heavily braced, optimally tuned, bass-reflex enclosure.

The XLT43E's robust crossover seamlessly integrates the acoustic outputs of the high and low frequency components. The PowerSense™ DDP (Dynamic Driver Protection) circuit monitors the power input to each driver and absorbs excessive power. A rear panel LED as well as front visible indication illuminate when the PowerSense™ circuitry is active, warning the operator of excessive power input. The crossover is built on a steel input panel and uses 250V film capacitors, precision inductors and high-grade circuit boards.

A Passive/Biamp switch allows easy switch-over between two modes of operation. In Passive mode a single amplifier channel is used to power the loudspeaker. In Biamp mode two amplifier channels are used to separately power the HF and LF sections. The frequency division is provided by the internal crossover, so no electronic crossover is needed. An HF Level switch can "voice" the system for different musical styles or room acoustics.

The XLT43E has two Neutrik Speakon NL4MP jacks and two 1/4" phone-type jacks. In Passive mode, all jacks are wired in parallel for easy daisy-chaining of two systems. The 4-pin Neutrik connector is used in Biamp mode for both the HF and LF inputs. The trapezoidal shape easily allows arraying two or more XLT43Es for wider coverage and increased acoustic output. Extended and increased bass output can be provided by the addition of the XLT55E dual 15" subwoofer. The XLT43E's footprint matches the XLT55E for easier stacking.

The recessed steel bar-handles, beveled 16 gauge perforated steel grille, and black paint exterior make this road-worthy system attractive, rugged and easily transportable. It has six engineered 3/8"-16 threaded captive-nut mounting/rigging points on its top and bottom and #10-24 T-nuts on its bottom for a stand adapter.

SPECIFICATIONS

Loudspeaker Type:

Two-way, Full-Range, Bass-Reflex System

Frequency Response: 50 Hz to 18 kHz

Power Handling:

Passive: 200W RMS; 500W Program

Biamp LF: 200W RMS; 500W Program

HF: 50W RMS; 125W Program

Sensitivity (1 Watt / 1 Meter):98.5 dB SPL

Nominal Dispersion: 90° Horizontal, 40° Vertical

Nominal Impedance:

Passive: 8 ohms; Biamp LF: 8 Ohms HF: 8 Ohms

Crossover Frequency(s):2 kHz

Drivers:

One 1 inch Titanium compression driver on a Pattern Control Horn

One 15 inch woofer, Ferrofluid-cooled

Speaker Protection:PowerSense DDP Input

Connectors (All wired in parallel):

Two Neutrik Speakon

Two 1/4 inch phone jacks

Enclosure Material and Finish:

Black painted 13-ply Baltic birch plywood

16 Gauge perforated steel grille and steel handles

Dimensions:

Height: 27 inches (686 mm)

Width - face: 20.25 inches (514 mm)

Width - rear: 13.25 inches (337 mm)

Depth: 18 inches (457 mm)

Weight: 67.5 lb. (30.6 kg.)

Shipping Weight:77 lb. (34.9 kg.)

XLT43E Page 1 of 2

COMMUNITY PROFESSIONAL LOUDSPEAKERS

333 East Fifth Street Chester, PA 19013-4511 USA Phone (610) 876-3400 Fax (610) 874-0190

© 1997, Community Light & Sound, Inc.



XLT43E

TWO-WAY COMPACT TRAPEZOIDAL LOUDSPEAKER SYSTEM

FREQUENCY RESPONSE

PASSIVE MODE

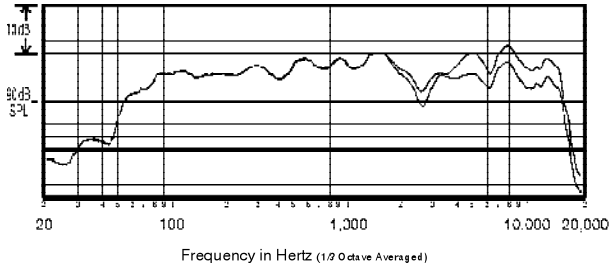

IMPEDANCE

PASSIVE MODE

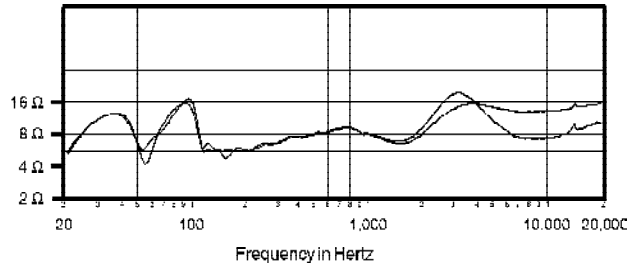

FREQUENCY RESPONSE

BIAMPLIFIED MODE

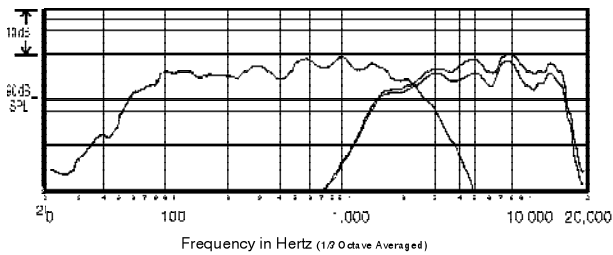

IMPEDANCE

BIAMPLIFIED MODE

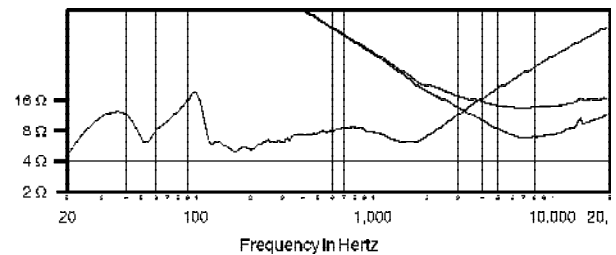

DIMENSIONS

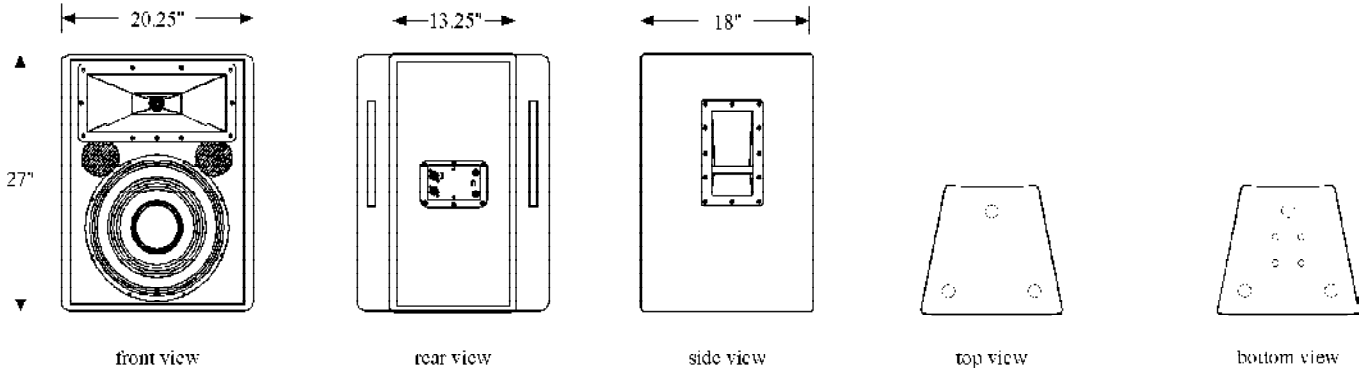

ARCHITECTS' AND ENGINEERS' SPECIFICATIONS

The loudspeaker system shall be a direct-radiating, bass-reflex design with one Ferrofluid-cooled 15 in. woofer and one 1 in. titanium diaphragm compression driver coupled to a Pattern Control horn. All components shall be connected to an integral crossover/protector. The crossover/protector shall be a two-way design with 12 dB/octave low pass at 2 kHz to the woofer and 12 dB/octave high-pass at 2 kHz to the high-frequency driver. The crossover shall utilize a steel input panel with Neutrik NL4MP and 1/4 in. jacks, glass-epoxy circuit boards, high quality 250V film capacitors, heavy air-core inductors, high positive current coefficient resistors (HPCCR's) for component protection, and front/rear overcurrent indicators. A Passive/Biamp switch shall allow operation using one or two amplifier channels without need of an electronic crossover. An HF level control shall be switchable between Flat and +4 dB. The loudspeaker enclosure shall be constructed of well-braced, black-painted, 3/4 inch (18mm) 13-ply Baltic birch, a 16 gauge perforated steel grille and two steel, recessed bar handles. The system shall meet the following performance criteria: Amplitude response of 50 Hz to 18,000 Hz, 200W RMS power handling, 98.5 dB sensitivity at 1 meter with one watt applied. The horn coverage pattern shall be 90° H x 40° V. The loudspeaker shall be 27 in. (686 mm) H x 20.25 in. (514 mm) W (front) x 13.25 in. (337 mm) W (rear) x 18 in. (457 mm) D and weigh 67.5 lb. (30.6 kg). The system impedance shall be 8 ohms nominal.

LIMITED WARRANTY

Community XLT/E loudspeaker systems are guaranteed to be free from defects in materials and workmanship for a period of five years from the original date of sale. Since the warranty applies to the product, the remainder of the warranty period will be automatically transferred to any subsequent owner. Only failures caused by defects in materials and workmanship are covered, not failures caused by abuse, accident, modification, improper handling/installation, or repairs made without factory authorization or by other than an authorized Community Field Service Station. Products covered by this warranty will be repaired or replaced at the option of Community, without charge for materials or labor, provided all the terms of this warranty have been met. This statement is a condensed version of the Community Product Warranty, intended for quick reference only. For complete warranty information, consult the product owners manual or call (610) 876-3400 for a copy.

PRELIMINARY SPECIFICATIONS.

XLT43E Page 2 of 2

COMMUNITY PROFESSIONAL LOUDSPEAKERS

333 East Fifth Street Chester, PA 19013-4511 USA Phone (610) 876-3400 Fax (610) 874-0190

9709024A