



CSX52-S2

THREE-WAY CARPETED LOUDSPEAKER SYSTEM

APPLICATIONS:

- Theatres
- Clubs
- Houses of Worship
- Sporting Facilities
- Entertainment
- Industrial A/V

FEATURES:

- High sensitivity, low distortion
- PowerSense™ Dynamic Driver Protection
- Wavefront Coherent™ design
- Black carpeted exterior

DESCRIPTION

The CSX52-S2™ is a rugged, high-sensitivity, three-way, full-range loudspeaker system. The system utilizes one PZT high-frequency driver coupled to a Pattern Control horn, one 6 1/2" midrange driver mounted to a compound horn. This MF/LF section can be rotated allowing horizontal mounting. This LF is a Ferrofluid-cooled 15" woofer for high sensitivity and excellent power handling capability. These components are matched to an optimally tuned direct radiating bass-reflex enclosure. The recessed handles, black carpeted exterior and injection molded corners also make this system attractive, rugged and easily transportable.

The CSX52-S2 offers a robust internal PowerSense Dynamic Driver Protection crossover. The PowerSense crossover is built to last with high quality 250 V film capacitors, inductors and military grade circuit boards. The proprietary PowerSense DDP protection circuit provides both over current and thermal protection without old fashioned fuses for added performance and reliability.

Designed as a stand-alone full-range loudspeaker system, the CSX52-S2 offers enough bass for most applications. For more demanding applications, extended bass can be achieved by adding a CSX-S2 subwoofer. Wavefront Coherent design assures proper signal alignment between all frequency bands while producing consistent directivity and unmatched sonic clarity.

Mounting is easily accomplished utilizing threaded inserts provided and optional mounting kits. This product should never be suspended by its handles. Consult the CSX-S2/CSV Installation Guide for safe and proper installation instructions.

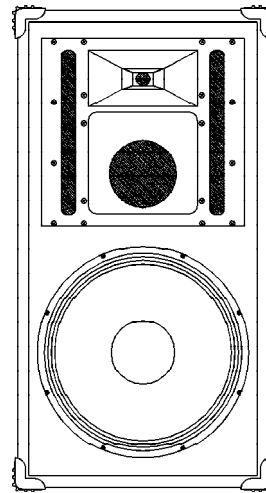

SPECIFICATIONS

Loudspeaker Type:

Three-Way, Full Range Bass Reflex System

Frequency Response: 40 Hz to 18 kHz

Power Handling: 200W RMS
500W Program

Sensitivity at 1W/1M: 98 dB SPL

Nominal Dispersion: 90° Horizontal, 60° Vertical

Nominal Impedance: 4 ohms

Crossover Frequencies: 500 Hz and 5 kHz

Drivers:

- One PZT on an exponential horn
- One 6 1/2" midrange on compound horn
- One 15" woofer, Ferrofluid-cooled

Speaker Protection: PowerSense DDP

Input Connections:

- Dual Neutrik Speakon in Parallel
- Dual 1/4 Phone Jacks in Parallel

Enclosure Material:

- Black carpet covered high density particle board
- 16 Gauge perforated steel grille

Dimensions:

- Height: 33.5 inches (851 mm.)
- Width: 18 inches (457 mm.)
- Depth: 18 inches (457 mm.)

Weight: 85 lbs. (38.6 kg.)

Shipping Weight: 94 lbs. (42.6 kg.)



CSX52-S2

THREE-WAY CARPETED LOUDSPEAKER SYSTEM

FREQUENCY RESPONSE

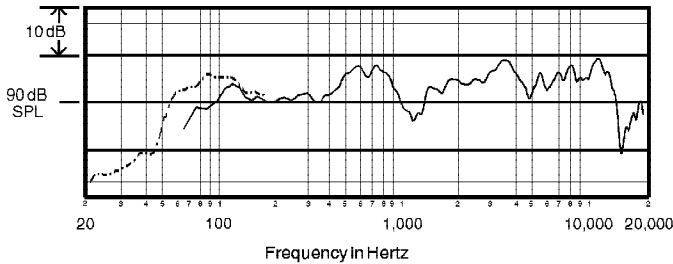

IMPEDANCE

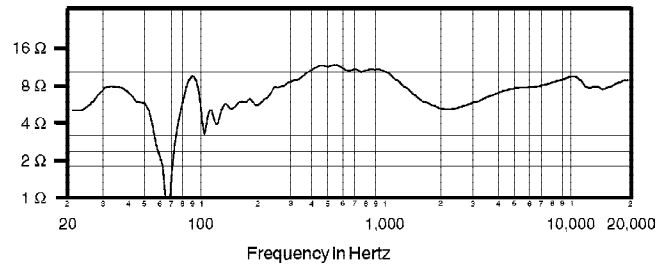

DIMENSIONS

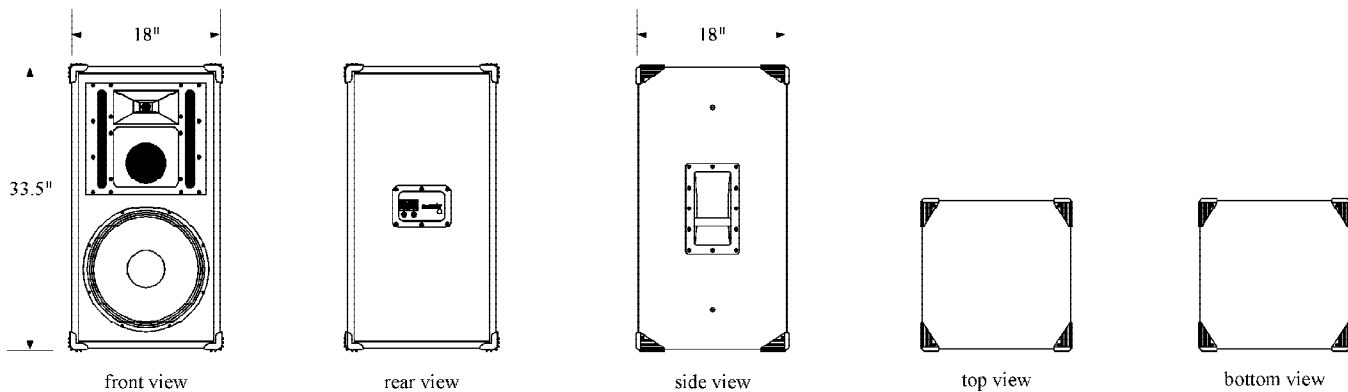

ARCHITECTS' AND ENGINEERS' SPECIFICATIONS

The loudspeaker system shall be a direct-radiating, bass-reflex design with one symmetric-field, Ferrofluid-cooled 15" woofer, one 6 1/2" midrange coupled to a Compound Horn and one PZT driver coupled to a pattern control horn. All components shall be Wavefront Coherent and be connected to an integral crossover/protector. The crossover/protector shall be a three-way design with 12 dB/octave low pass at 500 Hz to the woofer, 12 dB/octave band pass from 500 Hz to 5,000 Hz to the midrange and 12 dB/octave high-pass at 5,000 to the high-frequency driver. The crossover shall utilize high quality 250 V film capacitors, inductors and high positive current coefficient resistors (HPCCR's) for component protection. The loudspeaker enclosure shall have an internal volume of 4.6 cu. ft. (129.8 l) and be constructed of dense, well braced stock covered in black carpeting with eight injection molded corners and two built-in handles. The system shall meet the following performance criteria: Amplitude response of 40 Hz to 20,000 Hz +/- 5 dB, 200W RMS power handling, 98 dB sensitivity at 1 meter with one watt applied. Coverage pattern shall be 90° x 60° (HxV). Dimensions shall be 33.5" (851 mm) high, 18" (457 mm) wide, 18" (457 mm) deep, and weigh 85 lbs. (38.6 mm).

LIMITED WARRANTY

Community CSX-S2 Loudspeakers are guaranteed to be free from defects in materials and workmanship from the original date of sale for a period of ten years in the USA and a period of five years worldwide. Since the warranty applies to the product, the remainder of the warranty period will be automatically transferred to any subsequent owner.

Only failures caused by defects in materials and workmanship are covered, not failures caused by abuse, accident, modification, improper handling/installation, or repairs made without factory authorization or by other than an authorized Community Field Service Station. Products covered by this warranty will be repaired or replaced at the option of Community, without charge for materials or labor, provided all the terms of this warranty have been met.

This statement is a condensed version of the Community Product Warranty, intended for quick reference only. For complete warranty information, consult the product owners manual or call (610) 876-3400 for a copy.

PRELIMINARY SPECIFICATIONS