

SPECIFICATIONS (See notes 1 and 2)

Loudspeaker Type: 2-way, Full-range, bass ported, mini system

Operating Range: 70 Hz - 20 kHz
70 Hz - 20 kHz (+/-5dB)

Max Input Ratings: 100W continuous, 250W Program
28 volts RMS, 63 volts momentary peak
Transformer taps with 70Voption:
60 / 30 / 15 / 7.5 watts

Recommended Power Amplifier:
210W to 300W @ 8 Ohms

Sensitivity 1W/1m:
87dB SPL (80 Hz - 20 kHz 1/3 octave bands)
87dB SPL (250 Hz - 4 kHz speech range)

Maximum Output: 107 dB SPL / 114 dB SPL (peak)

Nominal Impedance: 8 Ohms

Min Impedance: 8.5 Ohms @ 14 kHz

Nominal -6 dB Beamwidth:
90° H (+24° / -23°, 1 kHz - 8 kHz)
90° V (+24° / -11°, 1 kHz - 8 kHz)

Axial Q / DI:
7.7 / 8.9, 1 kHz - 8 kHz

Crossover Frequency: 2 kHz

Recommended Signal Processing: 60 Hz high pass filter

Drivers:
LF (1) 8" cone, magnetically shielded
HF (1) 1" dome, magnetically shielded

Driver Protection:
PowerSense™ DDP

Input Connection:
(1) NL4 compatible jack (none with 70V option)
(1) 2 terminal barrier strip (5 terminals with 70Voption)

Controls: None

Enclosure: 19 mm MDF wood, painted (see options)

Enclosure Hardware: (1) integral handle

Mounting / Rigging Provisions:
(6) 1/4-20 rigging points
(4) 1/4-20 for stand adapter or mounting bracket

Grille: 16 gauge perforated steel (see options)

Required Accessories: None

Supplied Accessories: (1) Painted steel yoke bracket
(4) Rubber feet

Optional Accessories: None

Dimensions (without bracket):
Height: 11.8 in. / 300 mm
Width (front): 9.7 in. / 247 mm
Width (rear): 5.6 in. / 142 mm
Depth: 12.3 in. / 314 mm

Weight: 16 lb. / 7.3 kg

Shipping Weight: 20 lb. / 9.1 kg

1. Sensitivity: Free field pink noise measurement at 4 feet / 1.2m at 25% power; extrapolated to 1 meter and an input of 2.83V RMS.

2. Watts: All wattage figures are calculated using the rated nominal impedance.

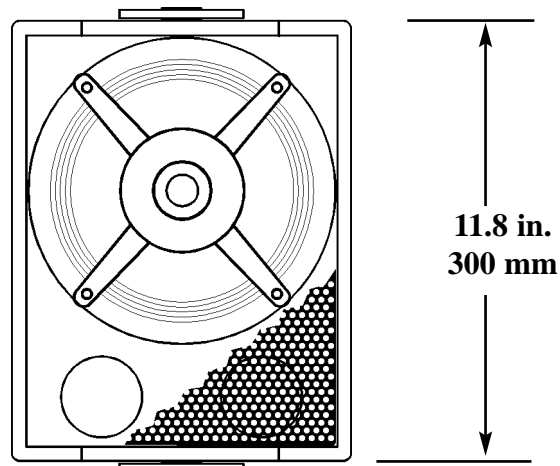

APPLICATIONS:

- Karaoke Clubs, Health Clubs
- Karaoke Clubs, Health Clubs
- Offices, Classrooms, Meeting rooms
- A/V systems, Retail Environments
- Amusement Parks
- Supplementary coverage for Houses of Worship, Auditoriums, Theatres, Music and Dance Clubs
- Distributed systems

FEATURES:

- Magnetically shielded for A/V
- Low "Q" dispersion
- Coaxially mounted HF Driver
- PowerSense™ DDP
- Ultra Compact Trapezoidal Enclosure
- Easy mounting with included Yoke

DESCRIPTION

The CPL23 is an ultra-compact, two-way full-range loudspeaker system with one 8 in. LF driver and one 1 in. dome HF driver coaxially mounted to the LF driver. This direct radiating loudspeaker is engineered for systems where high performance, cost-effectiveness and versatility are needed in a small package. The ultra-compact CPL loudspeakers are optimized for background / foreground music systems with enhanced announcement capability. Ultra-compact CPL systems have an integral steel mounting yoke and are available in either a white or black finish. They may be ordered with a 70V option that includes a 60 W transformer with taps at 60 W, 30 W, 15 W and 7.5 W. Five year limited warranty.

OPTIONS:

- CPL23-B: Black painted
- CPL23-BT: Black painted / 70V option
- CPL23-W: White painted, white cloth grille covering
- CPL23-WT: White painted / 70V option, white cloth grille covering

FREQUENCY RESPONSE

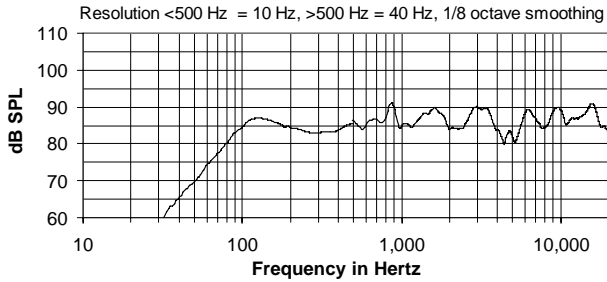

IMPEDANCE

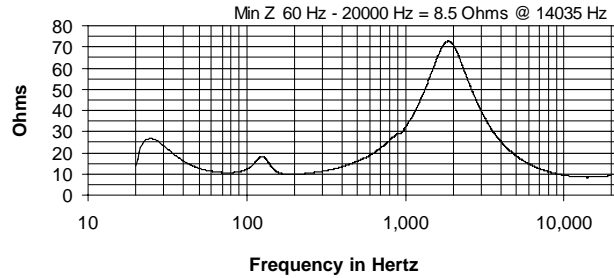

BEAMWIDTH

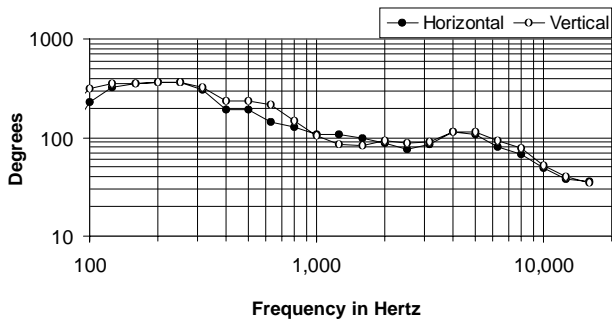

AXIAL Q

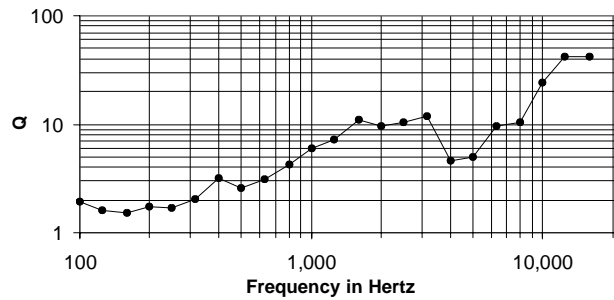

DIMENSIONS

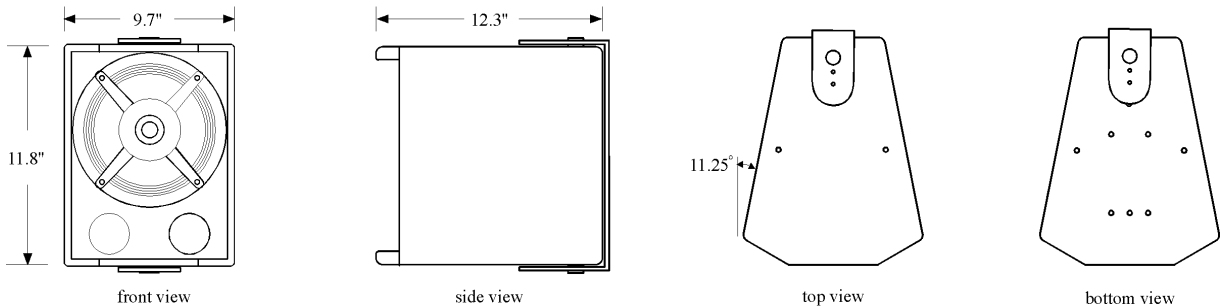

ARCHITECTS' AND ENGINEERS' SPECIFICATIONS

The loudspeaker system shall be a two-way, full-range bass reflex trapezoidal design with one 8 in. woofer and one 1 in. exit HF dome driver coaxially mounted to the LF speaker. Drivers shall be connected to an integral crossover with a crossover frequency of 2 kHz and integral over-current protection circuitry using high positive current coefficient resistors. There shall be one NL4 compatible [not on "T" model] and one two-terminal [five-terminal] barrier strip input connectors [and one 70V, 60W transformer]. The loudspeaker enclosure shall be MDF with a 16 gauge perforated steel grille {with a white cloth cover} and finished with black {white} paint. The system shall have an amplitude response of 70 Hz to 20 kHz (+/- 5 dB), input capability of 28V RMS, 87 dB sensitivity at one meter and 2.83V / 8 ohms [83, 167, 333, and 667 ohms] nominal impedance. The nominal dispersion shall be 90° H x 90° V from 1 kHz to 8 kHz. The loudspeaker shall be 11.8 in. (300 mm) H x 9.7 in. (247 mm) W (front) x 5.6 in. (142 mm) W (rear) x 12.3 in. (314 mm) D and weigh 16 lbs. (7.3 kg).